



by Wenger

Installation Instructions

GearBoss® II High Density Storage Side Closure Kit Accessory

Installation Instructions only! For Replacement Parts and more detailed product information, refer to the GearBoss II High Density Storage Assembly/Owner's Manual.

The Side Closure Kit Accessory closes off an open side of the Cart similar to the End Frame.

With two or more people working together, attach the Side Closure Kit as follows.

1. On the side of the Chassis with the holes at the bottom, remove the front two 5/16-18 x 5/8-inch Capscrews that secure the Roof to the Cart.
2. Attach the two Side Closures to the Top Bracket using five Top Plates and ten 1/4-20 x 1-1/4-inch Carriage Bolts and 1/4-inch Lock Nuts as shown.

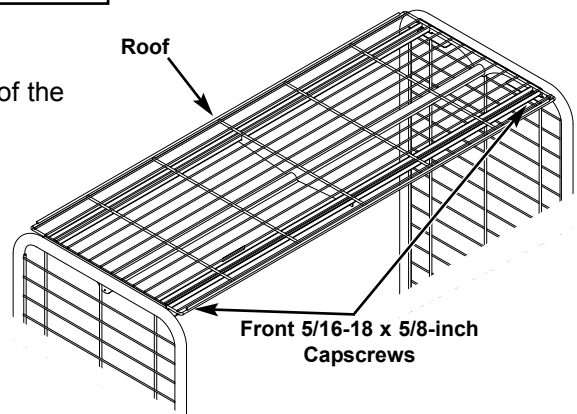

The center and two outside top plates must straddle the vertical wires with carriage bolts on both sides but mount **UNDER** the top horizontal wire.

The remaining two top plates must straddle the vertical wires with carriage bolts on both sides but mount **ABOVE** the top horizontal wire.

3. Attach the Mid Plate to the Side Closures using two Top Plates and four 1/4-20 x 1-1/4-inch Carriage Bolts and 1/4-inch Lock Nuts as shown.

The Mid Plate must straddle the Vertical Wires of both Closure Assemblies with a Carriage Bolt on both sides.

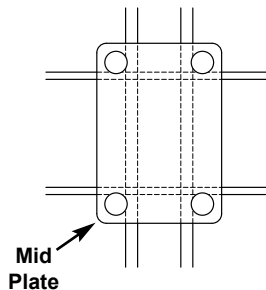
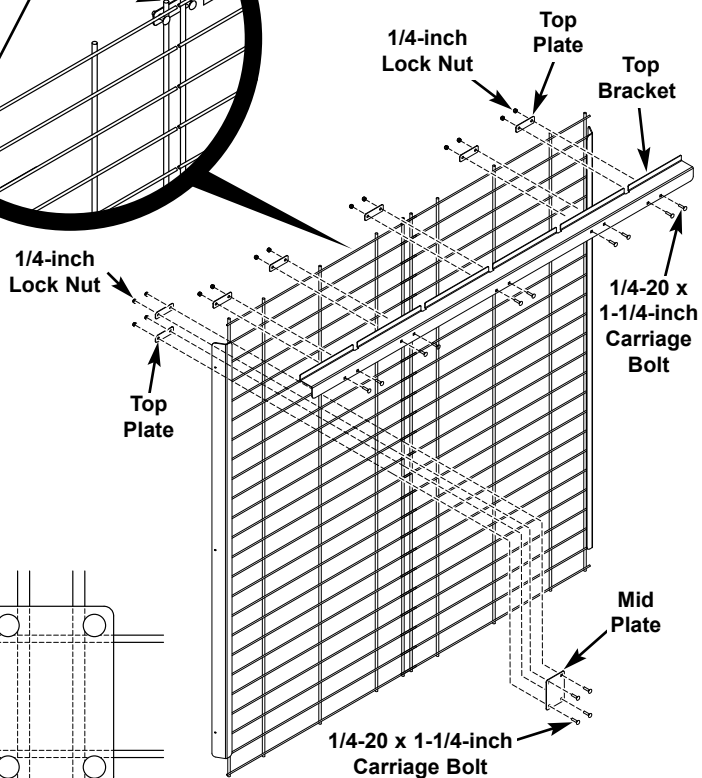
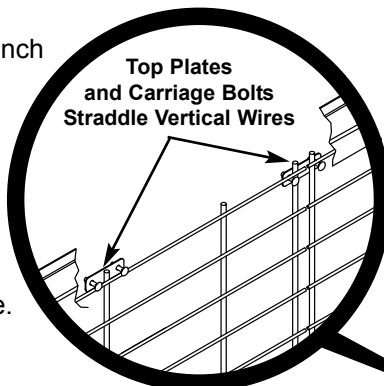

Continued on next page.

4. Insert the Vertical Wires at the bottom of the Closure Assembly with the holes in the Chassis Frame. Lift up on the Roof until there is enough clearance for the Top Bracket to fit underneath. The mounting surface of the Side Closure Assembly should sit flush on the End Frame Rail.

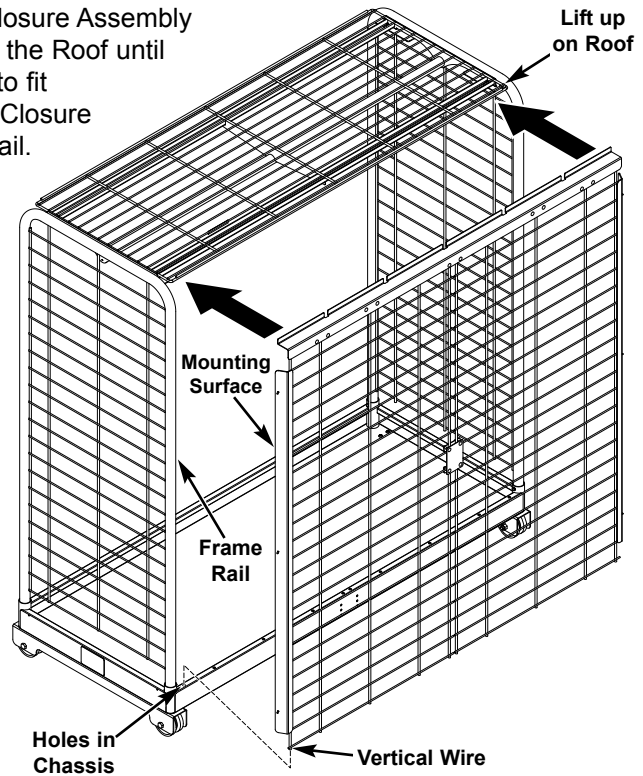
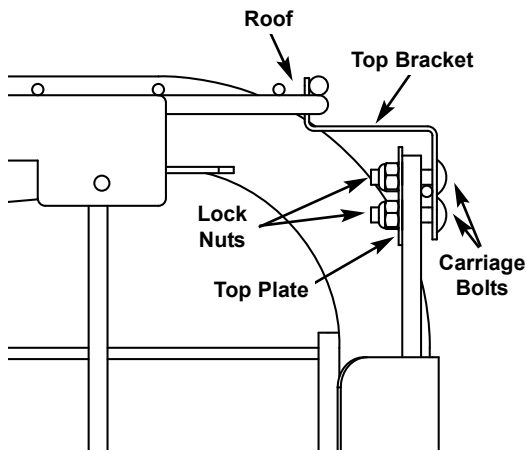

5. Attach the Side Closure Assembly to the End Frame Rail using one #10-16 x 3/4-inch Self Drilling Screws in each of the three holes on the mounting surface of the Side Closure Assembly.
6. Re-install the two 5/16-18 x 5/8-inch Capscrews that were removed in Step 1.

Note: Roof Assembly and End Frame Wires are not shown for clarity.

Use bracket as a guide and pre-drill six pilot holes using a 1/8" drill bit

